

CONTAINER - IBC HDPE

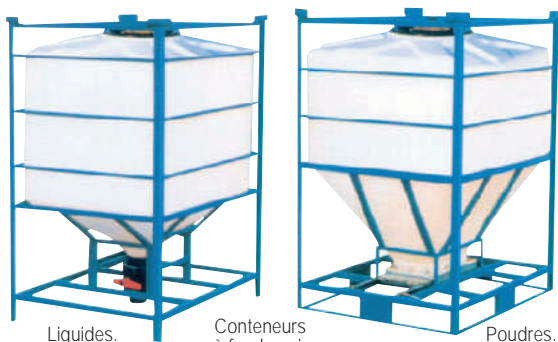

GTL / GTS

Cold rolled AISI 304 stainless steel container (AISI 316 on request); satin exterior finish and BA interior finish.
Cold-molded bottom with optimized profile minimum thickness 1.5 mm.
Automatic TIG welding, cleaned and passivated.
Bath-galvanized steel protection cage (AISI 304 on request).
Tank housing with anti-vibration rubber pads.
Palletized base with fork guides for forklift and manual pallet truck.
Stacking: max 2 full containers stacked.
Maximum permissible specific weight: 1.9 kg / dm³.
Do not stack full containers during transport.

Technical characteristics :

- (art. 000829) GTL model for liquid, volume 1.000 liters
- (art. 000830) GTS model for powder, volume 1.000 liters
- Fluted outer frame DN 400
- Metallic structure in carbon steel with epoxy paint
- Stackable up to 5 empty and 2 full containers
- Handling by pallet truck or elevator
- Thanks to the galvanized steel hatch and the DN 50 ball valve, the powder is emptied perfectly
- Capacity 1.000 liters

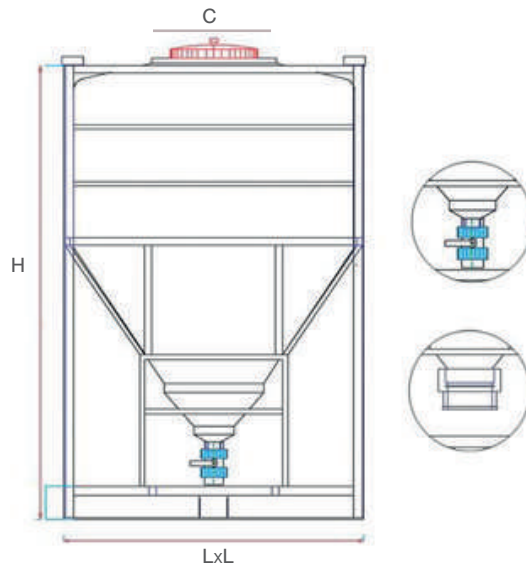

[ACCESSORIES AND OPTIONS]

- (art. 001043) Frame for container 1,000 liters painted
- (art. 001046) Frame for standard 1,000 liter hopper
- (art. 001047) 125x125 plate for container

TECHNICAL CHARACTERISTICS

ARTICLE	CAPACITY (L)	TYPE OF PRODUCT	HEIGHT (MM)	LXL (MM)	C (MM)
000829	1000	LQUIDE	1630	1200x930	400
000830	1000	POUDRE	1630	1200x930	400